

Operator's Manual

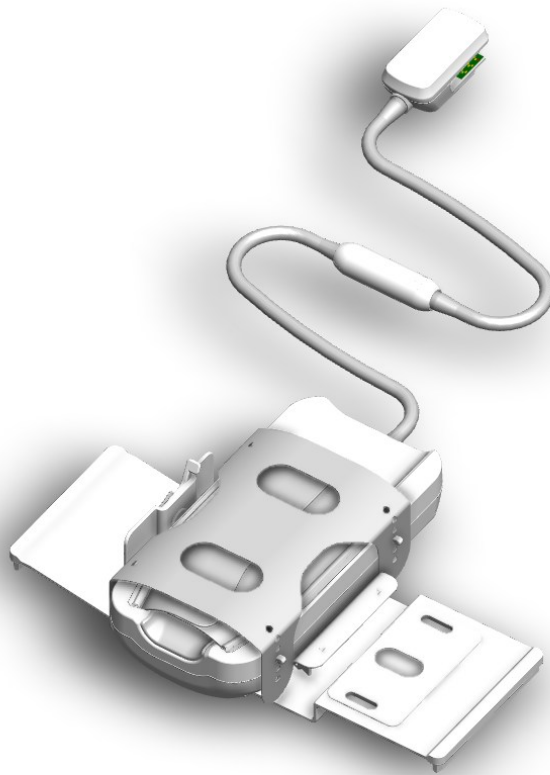

Contour Hand Wrist

For Siemens 0.55T MRI Systems



www.qualityelectrodynamics.com

REF	Q700232
-----	---------

Warranty and Liability

The responsibility for maintenance and management of the product after delivery resides with the customer who has purchased the product. The warranty does not cover the following items, even during the warranty period:



- Damage or loss due to misuse or abuse.
- Damage or loss caused by Acts of God such as fires, earthquakes, floods, lightning, etc.
- Damage or loss caused by failure to meet the specified conditions for this equipment, such as inadequate power supply, improper installation, or unacceptable environmental conditions.
- Damage due to changes or modifications made to the product.

In no event shall QED be liable for the following:

- Damage loss or problems caused by relocation, modification, or repair performed by personnel not explicitly authorized by QED.
- Damage or loss that results from negligence or from ignoring the precautions and operating instructions contained in this operation manual.

Transportation and Storage Conditions

This equipment shall be transported and stored under the following conditions:

	Temperature	-20°C to +60°C
	Relative humidity	10% to 90%



CAUTION

If the coil packaging is exposed to environmental conditions outside of the transportation and storage conditions, the packaging is damaged, or the packaging is opened prior to delivery, complete Quality Assurance testing prior to actual use. If the coil passes QA testing, it may be used normally.

United States Federal Law

Caution: Federal law restricts this device to sale, distribution, and use by or on the order of a physician. The device is limited by Federal Law to investigational use for indications not in the Indications Statement.

About This Manual

This manual contains detailed information on the safety precautions, use, and care of the RF Coil.

 CAUTION	For safety and accuracy in using the product, read and understand this manual as well as the MRI system user manual and safety manual prior to operation of the product. This manual does not include instructions or safety information on equipment not provided by QED, such as the MRI system. Please consult the MRI system manufacturer for information regarding non-QED equipment.
--	--

The operator's manual is available online as a PDF file at www.qualityelectrodynamics.com. To request a paper copy of the operator's manual, please email info@qualedyn.com or complete the contact form at www.qualityelectrodynamics.com.



www.qualityelectrodynamics.com

Legend

In this manual, the following symbols are used to indicate safety and other important instructions. The signal words and their meanings are defined below.



WARNING

Warning must be heeded to avoid a hazardous situation that could result in death or serious injury.



CAUTION

Caution is necessary to avoid a hazardous situation, which, if not avoided, could result in minor or moderate injury.



INFORMATION

Emphasizes important details or provides information on how to avoid operating errors or other potentially hazardous situation, which, if not observed, may result in property damage.

Table of Contents

About This Manual.....	3
Table of Contents.....	4
Chapter 1 – Introduction.....	5
1.1 Description.....	5
1.2 Operating Principle	5
1.3 Operating Environment and Compatibility.....	5
1.4 User Profile	5
1.5 Patient Information	5
1.6 Clinical Benefits.....	5
Chapter 2 – Contour Hand Wrist Coil Components.....	6
2.1 Included Components.....	6
2.2 Required Siemens Accessories (Sold Separately)	7
Chapter 3 – Safety.....	8
3.1 Symbol Glossary.....	8
3.2 Indications for Use	9
3.3 Contraindications.....	9
3.4 Precautions	9
3.5 Cautions – RF Coil	10
3.6 Cautions – Contour Hand Wrist Coil	12
3.7 Residual Risks and Undesirable Side-Effects.....	12
3.8 Emergency Procedures and Incident Reporting	12
Chapter 4 – Quality Assurance.....	13
Chapter 5 – Coil Setup and Use	17
5.1 Determine Scan Position and Set Baseplate Orientation	17
5.1.1 Changing Coil Position from Vertical to Horizontal Orientation	18
5.1.2 Changing Coil Position from Horizontal to Vertical Orientation	21
5.1.3 Adjusting Coil Position on the Base.....	24
5.2 Connect Contour Hand Wrist Coil to System.....	25
5.3 Position the Patient	26
5.3.1 Positioning the Patient in the Horizontal Orientation	26
5.3.2 Positioning the Patient in the Vertical Orientation.....	28
5.4 Proper Coil Storage	31
Chapter 6 – Cleaning, Maintenance, Service, and Disposal.....	32
6.1 Cleaning the RF Coil	32
6.2 Maintenance.....	33
6.3 Service.....	33
6.4 Disposal.....	34
6.5 Expected Service Life	34
Chapter 7 – Performance Characteristics	35
7.1 Technical Specifications	35
7.2 Guidance and Manufacturer’s Declaration – Electromagnetic Compatibility (EMC)	35
7.2.1 Classification	35
7.2.2 Environment and Compatibility	35
7.2.3 Electromagnetic Emission	36
7.2.4 Electromagnetic Immunity.....	36

Chapter 1 – Introduction

1.1 Description

The Contour Hand Wrist Coil is an accessory to the MRI system used to examine the hand and wrist.

1.2 Operating Principle

Receive RF coils use an array of coil elements to receive magnetic resonance signals generated in hydrogen nuclei (protons) in the human body. The received signals are amplified and transmitted to the MRI system, where they are processed into tomographic images by the computer.

1.3 Operating Environment and Compatibility

The Contour Hand Wrist Coil is intended to be used in conjunction Siemens 0.55T Free. MRI systems in a specialized healthcare facility.

1.4 User Profile

Operator – Radiological technologists, laboratory technologists, physicians.

User training – No special training is required to use this coil. However, Siemens Healthineers provides a comprehensive training course for MRI systems in order to instruct operators on the correct use of MRI systems. QED offers training for this coil upon request.

1.5 Patient Information

Age, health, condition – No special limitations.

Weight – 320kg or less (consult the operation manual for the MRI system, and if the maximum allowable patient's weight for the system is lower than that for this coil, priority must be given to the maximum weight for the system).

1.6 Clinical Benefits

Local RF coils are an accessory of the MRI system and are optimized for imaging of specific body regions, improving the quality and resolution of images produced by MRI systems. As an accessory of an MRI system, the clinical benefit of the RF coil is inherited from the MRI system. MRI can assist in diagnosis of a variety of patient conditions when interpreted by trained healthcare professionals.

Chapter 2 – Contour Hand Wrist Coil Components

2.1 Included Components

The Contour Hand Wrist is shipped with the parts shown below. Upon receipt, please ensure that all parts are included in the shipment. Please contact your Siemens Healthineers representative for replacement or replenishment of any accessories listed here.

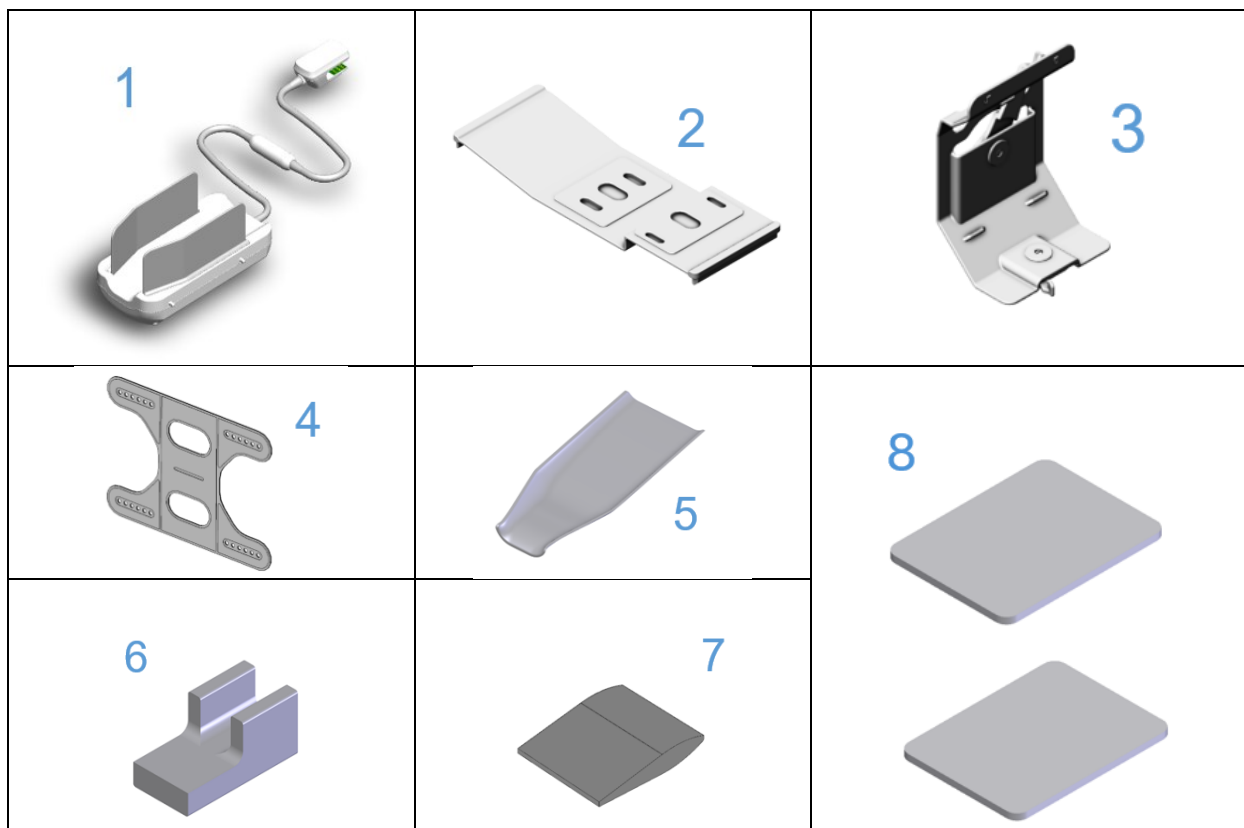

Item #	Description	Quantity	QED Part #
1	Contour Hand Wrist Coil	1	Q7000232
2	Baseplate - Contour Hand Wrist Coil	1	2004144
3	Shuttle - Contour Hand Wrist Coil	1	2004145
4	Strap - Contour Hand Wrist Coil	1	3008773
5	Liner Pad - Contour Hand Wrist Coil	1	3009672
6	Elbow Pad	1	3004607
7	Palm Pad	1	3004964
8	Positioner Pad	2	3009706

2.2 Required Siemens Accessories (Sold Separately)

The quality assurance procedure in this manual requires the following Siemens phantom. This phantom is provided standard with some Siemens MRI systems. QED does not provide this phantom. If this phantom is not available at your facility, please contact your Siemens Healthineers representative.

















Item #	Description	Quantity	Siemens Part #
1	Wrist/Hand Phantom 1100mL	1	10500498

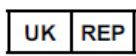

Chapter 3 – Safety

This section describes the general precautions and safety information that must be observed when this coil is used.

 CAUTION	<p>Before using the coil, review the safety information in the MRI system operation manual for a full list of safety considerations.</p>
---	--

3.1 Symbol Glossary

Symbol	Number	Standard	Title, Meaning
	1641	ISO 7000 IEC 60417	Operator's manual, Consult operating instructions before operating the device
	5172	ISO 7000 IEC 60417	Class II equipment
	5333	ISO 7000 IEC 60417	Type BF applied part
	3082	ISO 7000 IEC 60417	Manufacturer and Date of Manufacture
	6192	ISO 7000 IEC 60417	RF Coil, Receive
	N/A	IEC 60601-2-33 IEC 62570	MR Safe
	5.1.2	ISO 15223-1	Indicates the Authorized Representative in EU
	5.1.2	ISO 15223-1 ISO 20417	Indicates the UK Responsible Person
	5.1.2	ISO 15223-1 SwissMedic	Indicates the authorized representative in Switzerland
	2493	ISO 7000 IEC 60417	Catalog Number
	2498	ISO 7000 IEC 60417	Serial Number
	0632	ISO 7000 IEC 60417	Temperature limit
	2620	ISO 7000 IEC 60417	Humidity limitation
	2621	ISO 7000 IEC 60417	Atmospheric pressure limitation
	5.7.7	ISO 15223-1	Medical Device

Symbol	Number	Standard	Title, Meaning
	N/A	EN50419 EU2012/18/EU	The use of this symbol indicates that this product should not be treated as household waste. By ensuring that this product is disposed of correctly, you will help prevent potential negative consequences for the environment and human health, which could otherwise be caused by inappropriate waste handling of this product. For more detailed information concerning the return and recycling of this product, please consult the supplier from whom you purchased the product.
	5.1.8	ISO 15223-1	Importer
	5.1.9	ISO 15223-1	Distributor

3.2 Indications for Use

The Contour Hand Wrist Coil is intended for use with Siemens 0.55T MR systems to produce diagnostic images of the hand and wrist that can be interpreted by a trained physician.

3.3 Contraindications

None.

3.4 Precautions





Patients with increased likelihood of seizures or claustrophobia may require special care. Consult the MRI system operation manual.



Patients who are unconscious, heavily sedated, or in a confused mental state are at increased risk of burn injury because they may not be able to notify the operator of heat or pain due to excessive heating and tissue damage.









Patients with an inability to maintain reliable communications (for example, young children) are at increased risk of burn injury because they may not be able to notify the operator of heat or pain due to excessive heating and tissue damage.

-  Patients with loss of feeling in any body part are at increased risk of burn injury because they may not be able to notify the operator of heat or pain due to excessive heating and tissue damage.
-  Patients who have difficulty regulating their body temperature or who are particularly sensitive to increases in body temperature (for example, patients with fever, cardiac failure, or impaired perspiration) are at increased risk of burn injury or their body temperature may increase.
-  Ensure that the patient does not wear clothing that is wet or dampened by perspiration. The presence of moisture increases the risk of burn injury.

3.5 Cautions – RF Coil

-  Do not place any disconnected devices (RF coils, cables, etc.) in the gantry during scanning. Remove unneeded RF coils from the couchtop and confirm that RF coils in use are connected to the connector port before scanning.

Disconnected RF coils present during scanning can cause a high-frequency induction current loop to form, resulting in burn injury to the patient. In addition, devices may be damaged.
-  Connect only the designated RF coils to the RF coil connection port.
-  Do not use a defective RF coil, especially if the outer covering has been damaged or if metal parts are exposed. There is a risk of electric shock.
-  Do not attempt to change or modify the coil. Unauthorized modifications could result in burn injury, electric shock, or decreased image quality.
-  Do not cross or loop coil cables. A high-frequency current may form and burns may occur.
-  Ensure that the patient does not come into direct contact with the coil cables. Burn injuries may result due to the electric field that is generated in the RF coil when a high-frequency magnetic field is transmitted.
-  Do not allow the patient to form a loop with any body parts. Use pads to ensure that the patient's hands and legs do not touch the coil, MRI system, patient table, or another

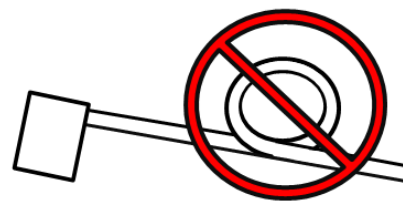

body part that may form a loop. A high-frequency current may form and burns may occur.

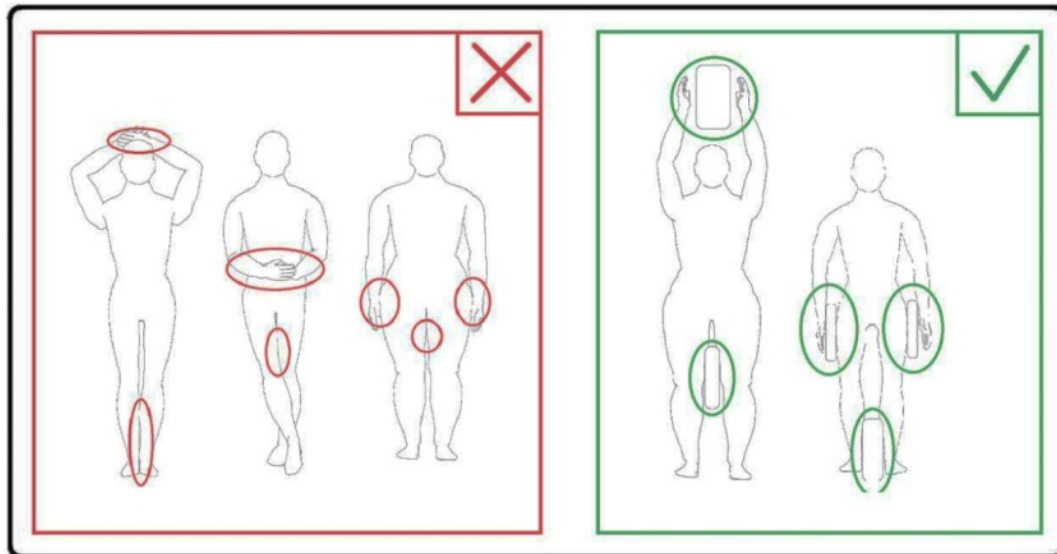

- ⚠ Do not allow the patient or RF coil to contact the gantry inner wall. Separate the patient from the gantry inner wall by at least 10 mm using foam pads. Separate the patient from the RF coil cable using foam pads. Burn injuries may result due to the electric field that is generated in the RF coil etc. when a high-frequency magnetic field is transmitted.
- ⚠ Confirm that the cable of the coil is on the couchtop before sending the patient into the gantry. If the couchtop is moved with the cable protruding, the cable may interfere with the MRI system main unit, which could result in shifting of the coil position or in the patient being caught and injured by the system.
- ⚠ Stop the scan immediately if the patient complains of warming, tingling, stinging, or similar sensations. Contact a physician before continuing with the scan.
- ⚠ Ensure that the coil does not come into contact with liquids, such as water or medications.
- ⚠ The enclosure of the coil and the parts inside the coil may appear in the images under certain imaging conditions (for example, when a sequence with a short echo time (TE) is used or when the pixels are large).
- ⚠ If a coil is found to be defective, stop using the coil immediately and contact your Siemens representative.
- ⚠ Use only the accessories described in this manual with the coil.
- ⚠ Electrostatic discharge could result in degradation of coil performance, resulting in reduced image quality and loss of diagnostic information. Follow the MRI system user

manual recommendations to mitigate ESD exposure, specifically regarding relative humidity, avoiding synthetic fabrics, etc.

3.6 Cautions – Contour Hand Wrist Coil



Do not store items on top of the Contour Hand Wrist Coil. Weight applied to coil flaps may lead to damaged electronics and loss of functionality of the coil.

3.7 Residual Risks and Undesirable Side-Effects

All known risks associated with RF coils have been controlled as far as possible. The benefit of the device has been determined to far outweigh the risk and residual risks are low. Residual risks are communicated through cautionary statements within this manual.

RF coils have no known undesirable side-effects aside from those attributed to the MRI examination. Refer to the MRI system operation manual.

3.8 Emergency Procedures and Incident Reporting

In case of an emergency during the scan, stop the scan immediately, remove the patient from the room, and obtain medical assistance, if necessary.

If a serious incident occurs in the EU, it should be reported to the manufacturer and the Competent Authority of the Member State in which the user facility is established.

Chapter 4 – Quality Assurance

Remove all coils and pads from the couch top.

- (1) Setup the baseplate, shuttle assembly, and Contour Hand Wrist coil in the horizontal orientation as described in section 5.1.1. Make sure in step (5) of 5.1.1 to orient the shuttle assembly perpendicular to the bore of the system. The shuttle assembly orientation can be adjusted through the procedure in section 5.1.3.
- (2) Place Siemens Wrist/Hand Phantom 1100mL (PN 10500498) into the Contour Hand Wrist coil.
- (3) Secure the coil to the phantom using the coil strap.

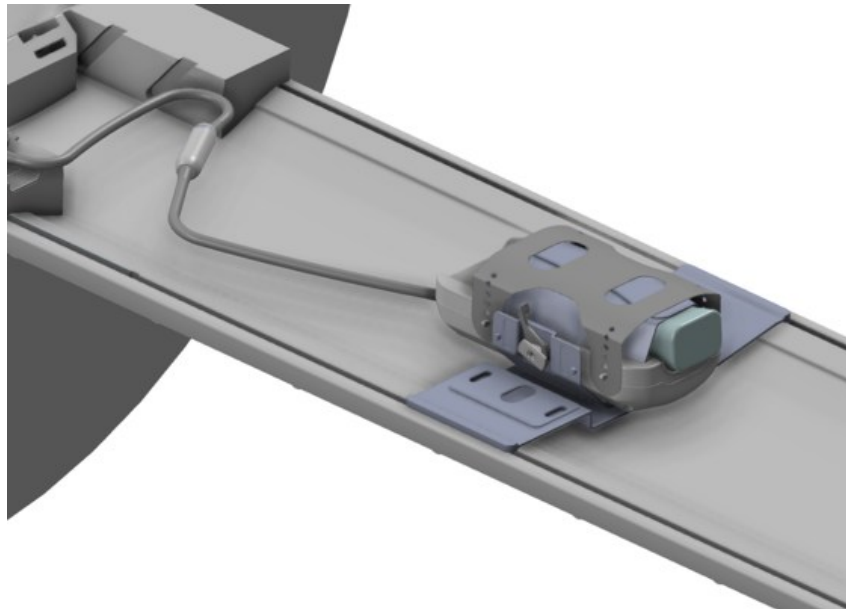

- (4) Move the coil into the magnet isocenter.
- (5) Register patient head first supine
- (6) Select a localizer. Ensure the imaging FOV corresponds with that of the coil.
 - a. Adjust frequency.
 - b. B0 shimming
 - c. Adjust Frequency
 - d. Close
 - e. Run Localizer

(7) Open the **se15b130** sequence.

- a. Rename sequence **se15b130_data_QED000232_SNxxxxx** (substitute "xxxxx" with the coil serial number)
- b. Choose transverse orientation.
- c. Choose 3 slices, -80mm (L=80), 0mm (S=0.0), +80mm (H=80)
- d. slice thickness SL=5mm, FOV = 220mm, 256x256 matrix, IPAT = no,
- e. Ensure the spine coil is deselected.
- f. Run the Sequence

(8) Open the **se15b130** sequence.

- a. Rename sequence **se15b130_noise_QED000232_SNxxxxx** (substitute "xxxxx" with the coil serial number)
- b. Do not modify the position on the screen
- c. Choose transverse orientation.
- d. Choose 3 slices, -80mm (L=80), 0mm (S=0.0), +80mm (H=80)
- e. SL=5mm slice thickness, FOV = 220mm, 256x256 matrix, IPAT = no,
- f. Go to System → TxRx Tab → Reference Voltage → RF Pulses → set both pulse amplitudes V=0
- g. Ensure the spine coil is deselected.
- h. Run the Sequence

(9) Calculate the signal values at all 3 slices of **se15b130_data_QED000232_SNxxxxx**

- a. Choose the slice at -80mm (L=80)
- b. Place a circular ROI measurement of radius 0.49cm [± 0.10 cm] at the center of the phantom.
- c. Record the mean signal value in the ROI (Signal_L)
- d. Choose the slice at 0mm (S=0.0)
- e. Place a circular ROI measurement of radius 0.49cm [± 0.10 cm] at the center of the phantom.
- f. Record the mean signal value in the ROI (Signal₀)
- g. Choose the slice at +80mm (H=80)
- h. Place a circular ROI measurement of radius 0.49cm [± 0.10 cm] at the center of the phantom.
- i. Record the mean signal value in the ROI (Signal_H)

(10) Calculate the noise values at all 3 slices of **se15b130_noise_QED000232_SNxxxxx**

- a. Choose the slice at -80mm (L=80)
- b. Place a circular ROI measurement of radius 9.0cm [± 0.5 cm] at the center of the FOV.
- c. Record the standard deviation value in the ROI (Noise_L)
- d. Choose the slice at 0mm (S=0.0)
- e. Place a circular ROI measurement of radius 9.0cm [± 0.5 cm] in the center of the phantom.
- f. Record the standard deviation value in the ROI (Noise₀)
- g. Choose the slice at +80mm (H=80)
- h. Place a circular ROI measurement of radius 9.0cm [± 0.5 cm] in the center of the phantom.
- i. Record the standard deviation value in the ROI (Noise_H)

(11) Calculate $SNR_L = \text{Signal}_L / \text{Noise}_L$

(12) Confirm $SNR_L \geq 100.0$

- (13) Calculate $SNR_0 = \text{Signal}_0 / \text{Noise}_0$
- (14) Confirm $SNR_0 \geq 100.0$
- (15) Calculate $SNR_H = \text{Signal}_H / \text{Noise}_H$
- (16) Confirm $SNR_H \geq 100.0$
- (17) Choose the **gre** sequence.
- Name the sequence **gre_data_QED000232_SNxxxxx** (substitute "xxxxx" with the coil serial number)
 - FOV 250mm, Single slice Isocenter, Coronal orientation,
 - Go to System → Miscellaneous → Coil Combination → open submenu (3 dots) → check Save Uncombined
 - Run the sequence
- (18) Open the viewer as a mosaic and confirm all channels are present.
- (19) Choose the **gre** sequence.
- Name the sequence **gre_noise_QED000232_SNxxxxx** (substitute "xxxxx" with the coil serial number)
 - FOV 250mm, Single slice (Isocenter), Coronal orientation
 - Go to System → Miscellaneous → Coil Combination → open submenu (3 dots) → check Save Uncombined
 - Go to System → TxRx Tab → Reference Voltage → RF Pulses → set both pulse amplitudes V=0
 - Run the sequence
- (20) Open the viewer as a mosaic and confirm there are no artifacts on the noise.

Chapter 5 – Coil Setup and Use

5.1 Determine Scan Position and Set Baseplate Orientation

The Contour Hand Wrist Coil is designed to image the patient either at the patient's side (vertical orientation) or over the patient's head (horizontal orientation). The base is comprised of two parts, the "baseplate" and the "shuttle". The base can be adjusted to accommodate either of these orientations by repositioning the shuttle. Determine optimal scan position based on patient size, comfort, and scan preference. Then set the base orientation based on desired patient scan position using the applicable instructions below.

Baseplate – Horizontal Orientation

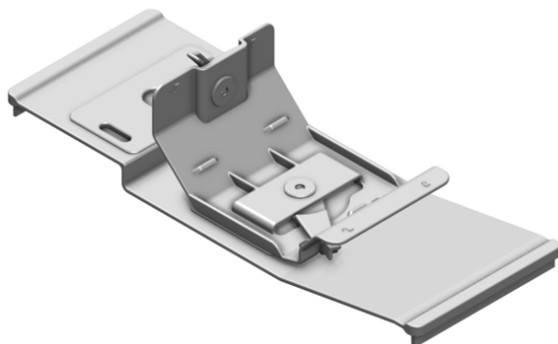

Baseplate – Vertical Orientation

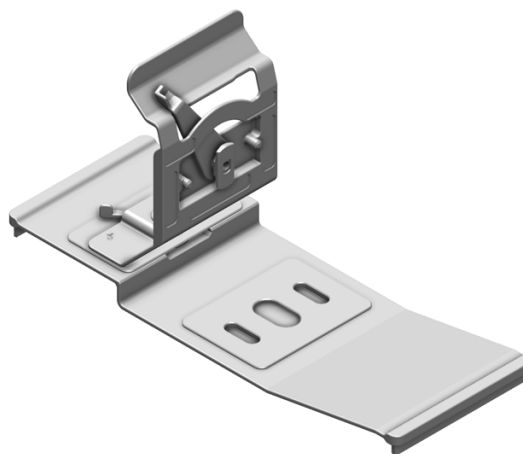

CAUTION

Do not switch orientation while the patient is in the coil.

5.1.1 Changing Coil Position from Vertical to Horizontal Orientation

- (1) Place the coil, shuttle, and baseplate assembly onto the system couchtop.

Assembly on Couchtop, Vertical Orientation



- (2) Remove the Contour Hand Wrist coil from the baseplate by holding the coil and firmly pushing on the coil release lever, as shown below.

Baseplate, Vertical Orientation

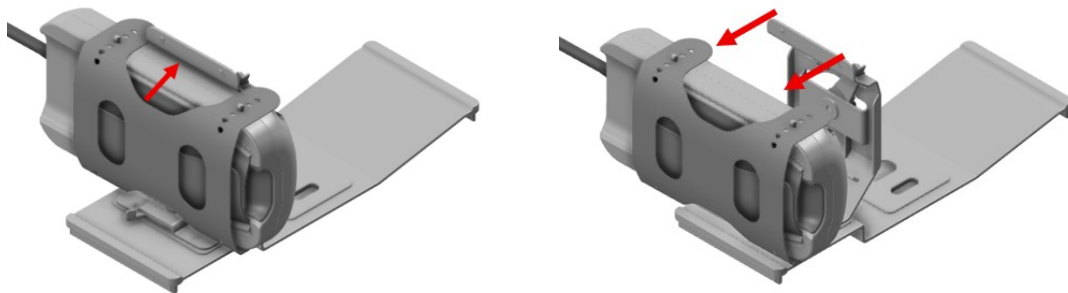

- (3) Remove the coil shuttle from the baseplate by rotating the latch to the unlock position and lifting the coil shuttle from the baseplate.

Unlock the Coil Shuttle

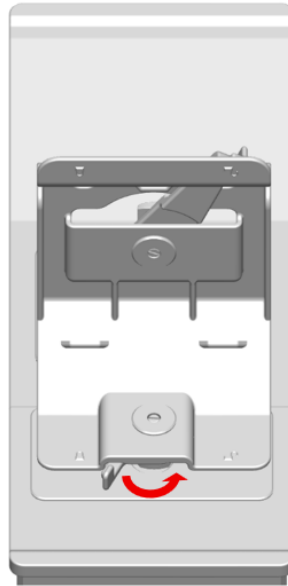

- (4) Rotate the coil shuttle downward and align the catch and studs with the central slots on the baseplate.

Rotate and Align Coil Shuttle

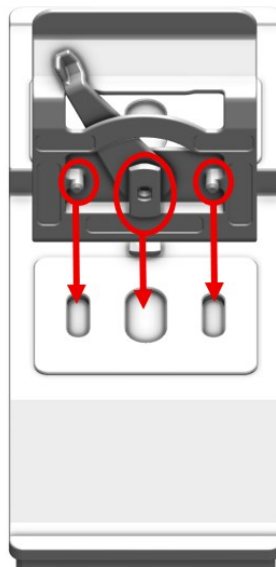

- (5) Place the coil shuttle in the appropriate position based on the patient hand/wrist to be imaged. Lock the coil shuttle to the baseplate by moving the locking lever from the unlocked to locked position.

Lock the Coil Shuttle

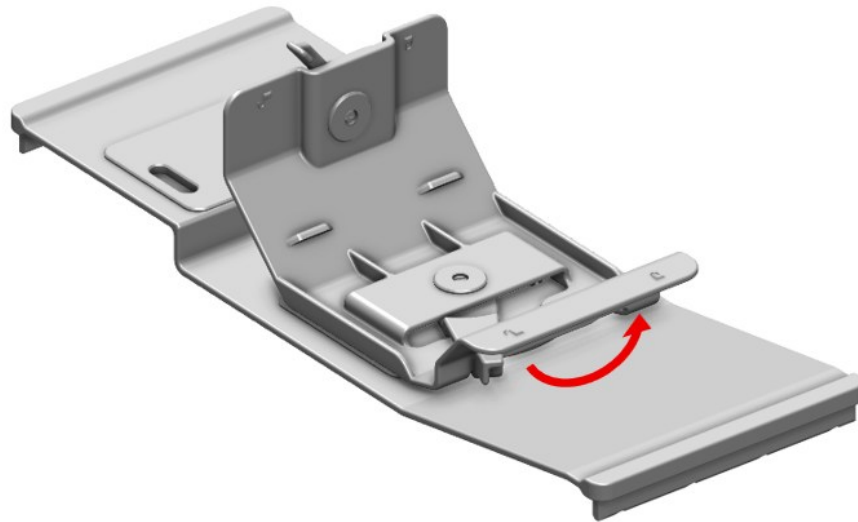

- (6) Install coil in the horizontal orientation by aligning the coil with the coil shuttle and pushing towards the support until the coil locks into the coil shuttle.

Install Coil onto Coil Shuttle

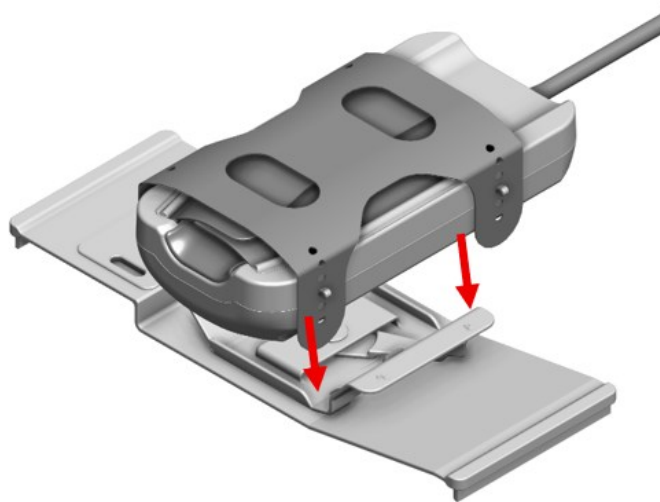

5.1.2 Changing Coil Position from Horizontal to Vertical Orientation

- (1) Place the coil, shuttle, and baseplate assembly onto the system couchtop.

Assembly on Couchtop, Horizontal Orientation



- (2) Remove the Contour Hand Wrist coil from the baseplate by holding the coil and firmly pushing on the coil release lever, as shown below.

Baseplate, Vertical Orientation

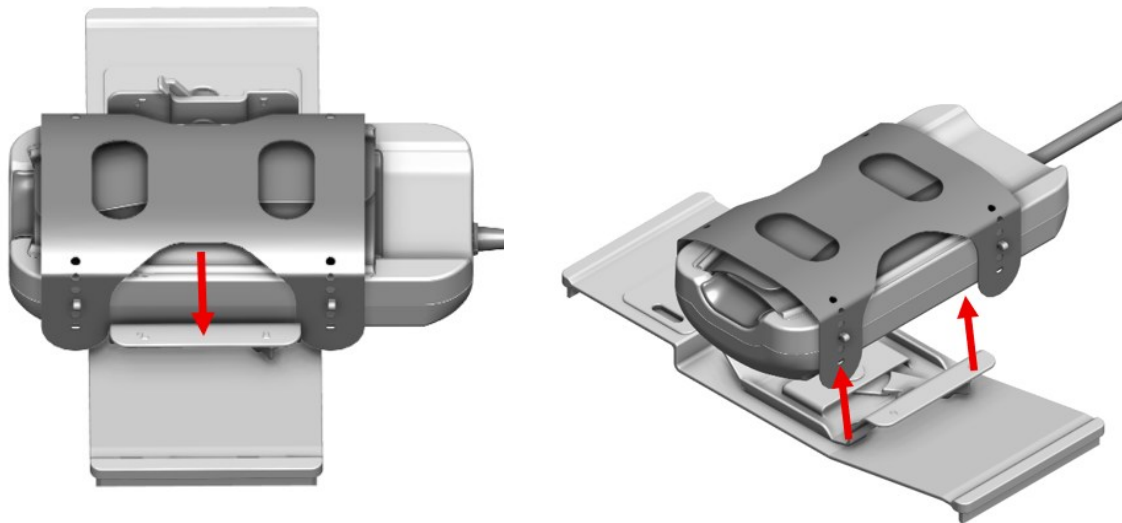

- (3) Remove the coil shuttle from the baseplate by rotating the latch to the unlock position and lifting the coil shuttle from the baseplate.

Unlock the Coil Shuttle

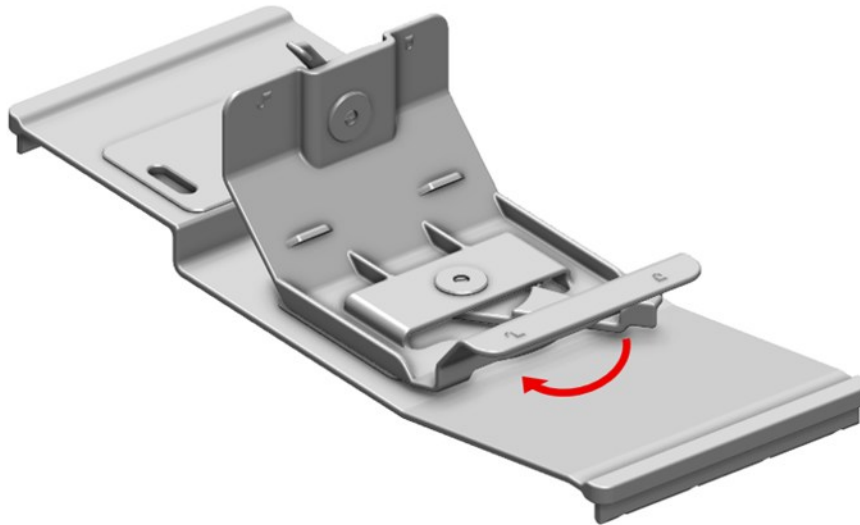

- (4) Rotate the coil shuttle downward and align the catch and studs with the off-center slots on the baseplate.

Rotate and Align Coil Shuttle

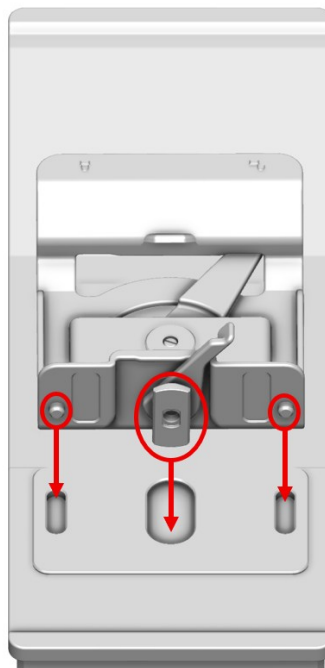

- (5) Place the coil shuttle in the appropriate position based on the patient hand/wrist to be imaged. Lock the coil shuttle to the baseplate by moving the locking lever from the unlocked to locked position.

Lock the Coil Shuttle

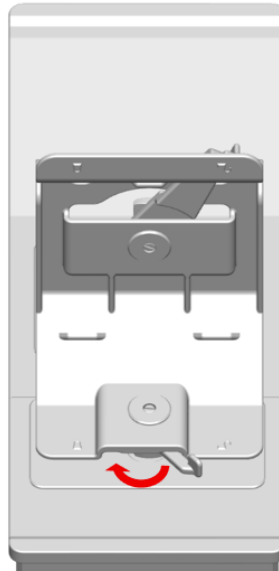

- (6) Install coil in the vertical orientation by aligning the coil with the coil shuttle and pushing towards the shuttle until the coil locks into the coil support.

Install Coil onto Coil Shuttle

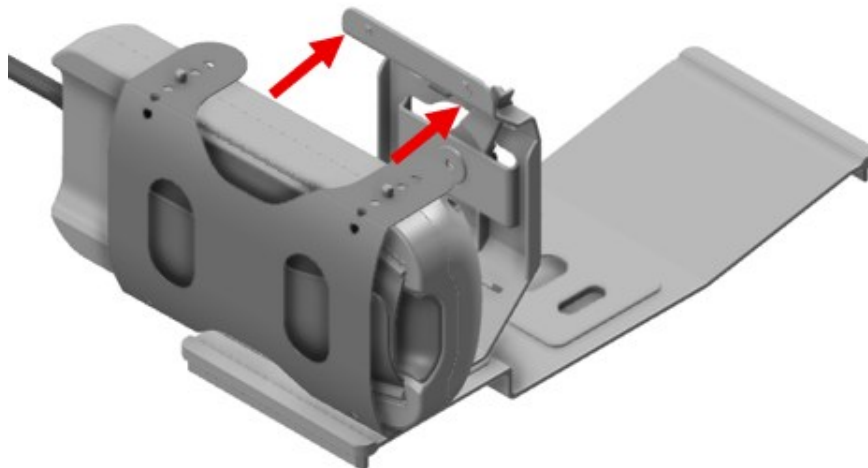

5.1.3 Adjusting Coil Position on the Base

If coil position adjustment is required, move the locking lever into the unlocked position, as shown below, to achieve desired alignment. The coil is also capable of being adjusted 15 degrees in either direction. Move the locking lever again to the lock position to secure the coil in place once the coil has reached the desired position.

Unlock – Baseplate, Horizontal Scan

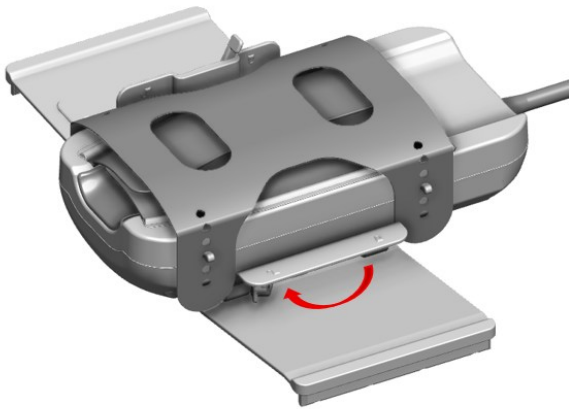

Lock – Baseplate, Horizontal Scan

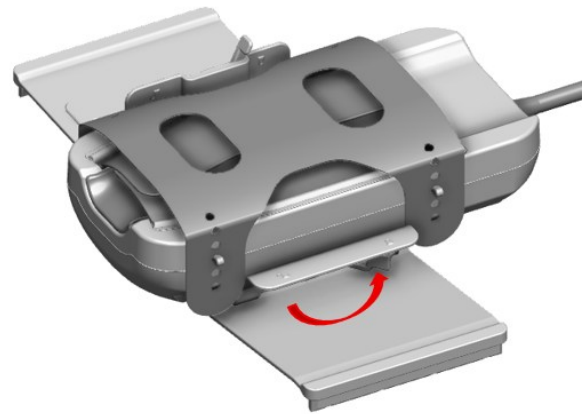

Unlock – Baseplate, Vertical Scan

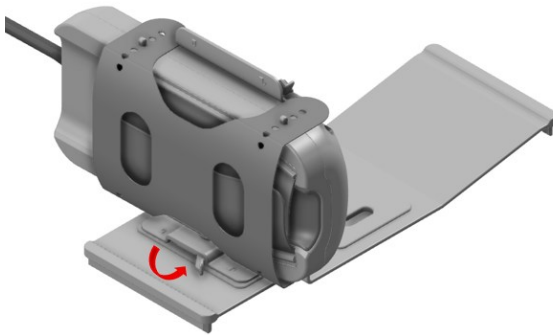

Lock – Baseplate, Vertical Scan

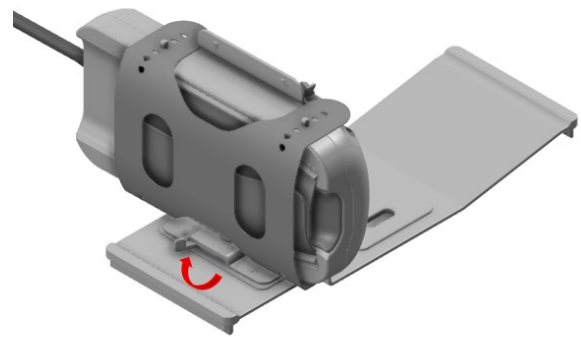

CAUTION



Ensure the baseplate is locked after any adjustment. If the baseplate is unlocked, the coil may shift during scanning, which could result in poor image quality.

5.2 Connect Contour Hand Wrist Coil to System

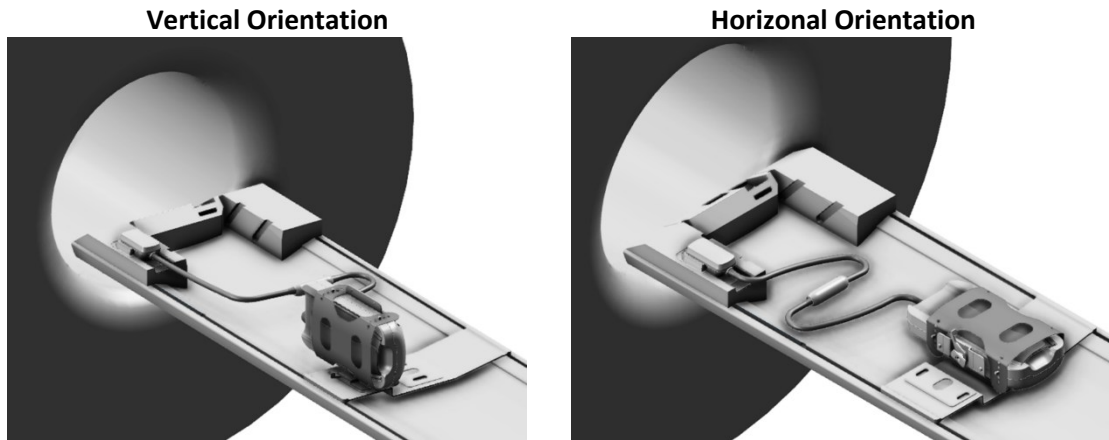
- (1) Remove any other surface coils (if present) from the couch top.
- (2) Transport the coil to the couch top. Be sure to carry the coil with both hands by the sides of the baseplate.
- (3) Place the coil onto the couch top. Note that the coil system cable should be pointing **towards** the bore.



- (4) Connect the coil connector to the appropriate port of the system. (Refer to system user manual for Port Location).

 CAUTION	Do not cross or loop coil cables.
 CAUTION	Ensure that patient does not come into direct contact with the coil cables.

5.3 Position the Patient

5.3.1 Positioning the Patient in the Horizontal Orientation

- (1) Setup the Contour Hand Wrist coil in the horizontal orientation shown in section 5.2.
- (2) Guide patient to lay on system couch head-first in the prone position.



- (3) Position the patient's hand into the coil.
 - a. If necessary, use a Palm Pad, Liner Pad, and/or Elbow Pad to ensure patient comfort.

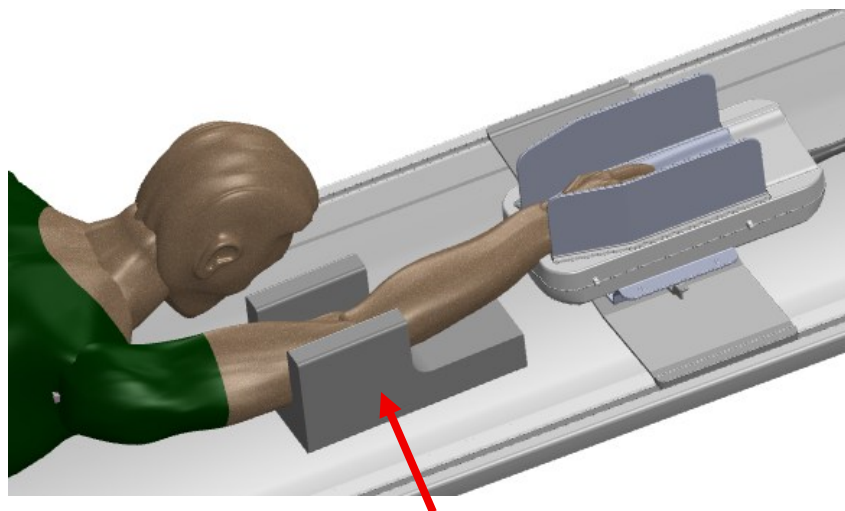

Elbow Pad

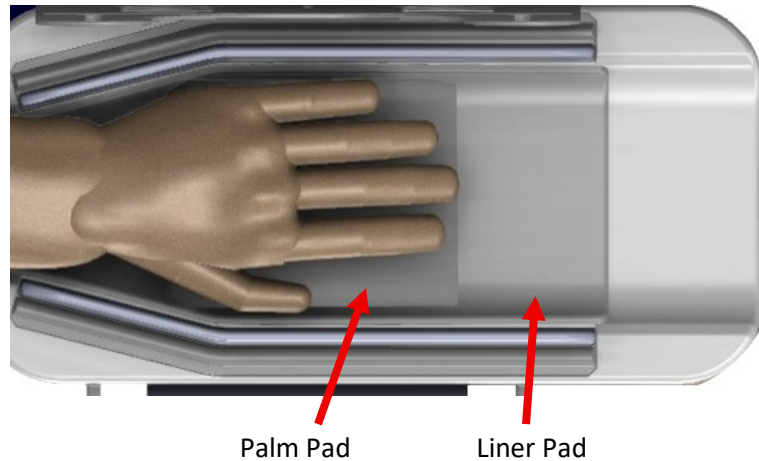

- (4) Secure the flaps around the patient using the coil strap. Ensure a firm strap fit so that patient movement is limited.

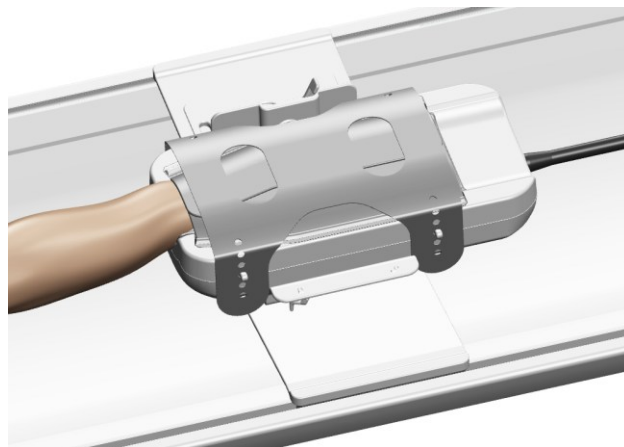

- (5) Confirm no parts of the coil, mats, etc. extend beyond the couch, and then raise the couch.
- (6) Confirm the patient and the cable are not in direct contact. Then, connect the cable connector to the port on the couchtop.
- (7) Select the region of interest.
- (8) Confirm that no parts of the coil, cable, mats, etc. extend out from the couchtop, and then move the patient into the gantry.
- (9) Register the patient.
- (10) Start scanning per the instructions in the MRI system manual.

5.3.2 Positioning the Patient in the Vertical Orientation

- (1) Set up the Contour Hand Wrist coil in the vertical orientation shown in section 5.2.
- (2) Affix the coil strap to the two notches that will be oriented downward in the vertical coil setup.

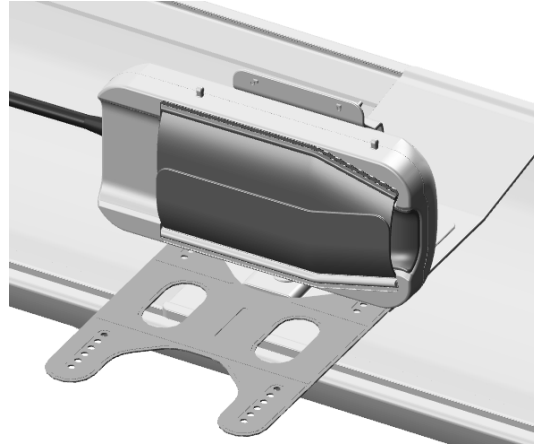

- (3) Guide patient to lay foot-first supine on system couch. Adjust patient positioning such that the patient's hand can be placed comfortably into the coil.

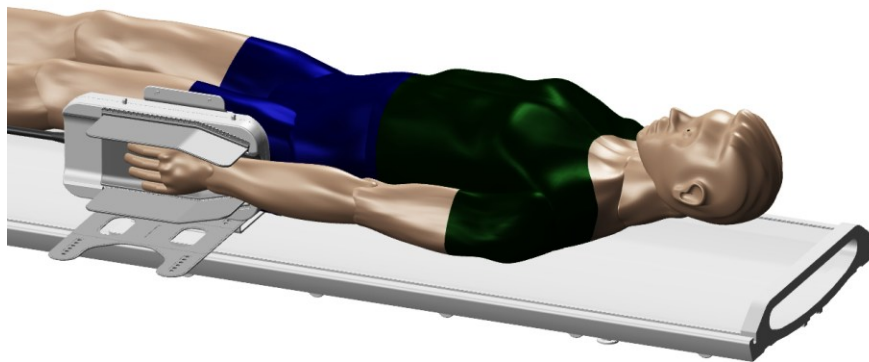

- a. If necessary, place positioner pads between the coil shuttle and patient and/or on top of the base to ensure patient comfort.

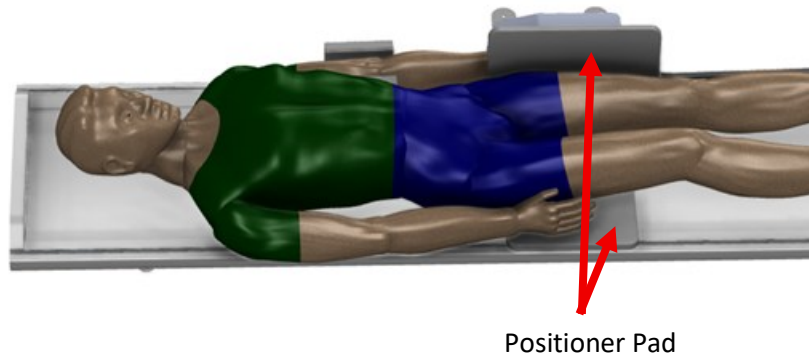

- (4) Position the patient's hand into the coil.

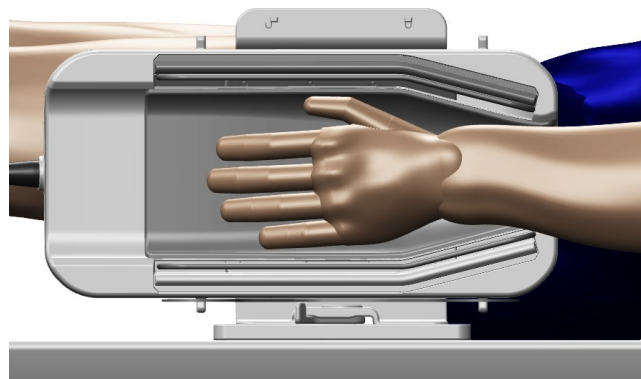

- a. If necessary, use a Palm Pad, Liner Pad, and/or Elbow Pad to ensure patient comfort.



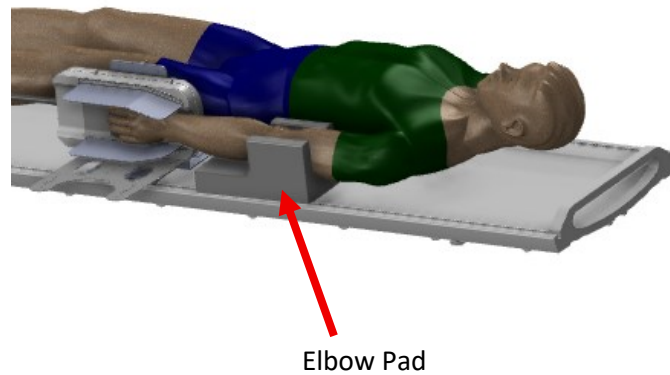

- (5) Fold both flaps of the coil over the hand and affix the strap to the notches of the coil that face upward. Choose positioning holes on the strap such that the fit is firm and patient movement is limited.



- (6) Confirm no parts of the coil, mats, etc. extend beyond the couch, and then raise the couch.
- (7) Confirm the patient and the cable are not in direct contact. Then, connect the cable connector to the port on the couchtop.
- (8) Select the region of interest.
- (9) Confirm that no parts of the coil, cable, mats, etc. extend out from the couchtop, and then move the patient into the gantry.
- (10) Register the patient.
- (11) Start scanning per the instructions in the MRI system manual.

5.4 Proper Coil Storage

Store the Contour Hand Wrist Coil with flaps folded inwards. The coil may be stored with or without the strap applied.

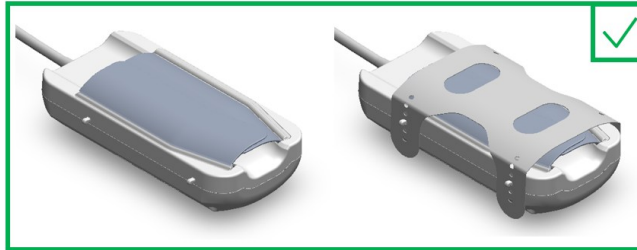

Do NOT store the Contour Hand Wrist with the coil resting on its flaps or with the flaps splayed outwards.

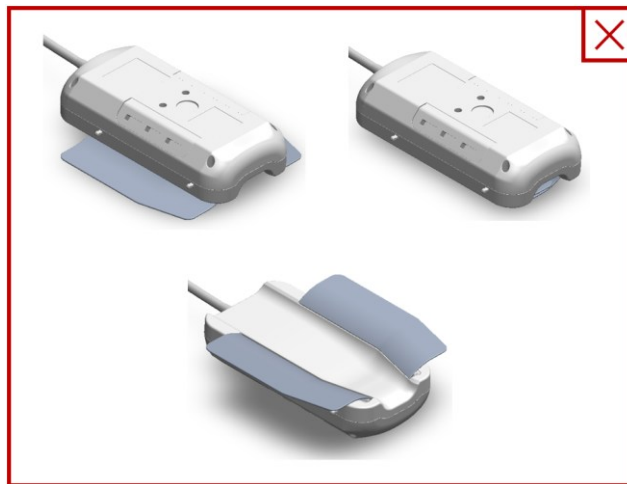

Do not store items on top of the Contour Hand Wrist Coil. Weight applied to coil flaps may lead to damaged electronics and loss of functionality of the coil.

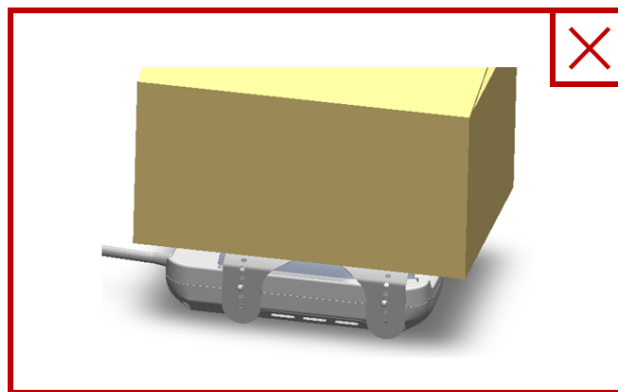

Chapter 6 – Cleaning, Maintenance, Service, and Disposal

6.1 Cleaning the RF Coil

Surfaces that could have contacted the patient, personnel, or bodily fluids should be cleaned and disinfected after each use.

Use a peroxide-based disinfectant with proven cleaning efficacy that is certified by relevant national authorities (EPA, VAH) for cleaning and disinfection. The cleaning and disinfection instructions below were validated using the following product:

- Clorox Healthcare Hydrogen Peroxide Cleaner Disinfectant Wipes

Cleaning and Disinfection Precautions

- ⚠ Do not pour or spray cleaning fluids onto surfaces.
- ⚠ Do not immerse objects in water or cleaning fluids.
- ⚠ Do not place into any type of sterilizer.
- ⚠ Ensure that no liquids seep into the openings of the product, for example, gaps between covers.
- ⚠ Do not use hard or sharp objects (for example, knives or tweezers) to remove residue.
- ⚠ Do not insert any objects into areas that are hard to reach.
- ⚠ Do not wipe electrical contacts or outlets. Cover electrical contacts before cleaning, if possible.
- ⚠ Avoid wiping affixed hook and loop surfaces; detachment may occur.
- ⚠ Wear appropriate personal protective equipment per the cleaner or disinfectant manufacturer's instructions.
- ⚠ Use only commercially available cleaning and disinfectant solutions. Follow the instructions provided by the manufacturer of the cleaning or disinfectant agent.
- ⚠ Use only the recommended cleaning agents; incompatible cleaning agents may cause surface damage or discoloration.

Preparation

- (1) Disconnect device before coil cleaning.
- (2) If any parts of the device are detachable, detach them and clean and disinfect separately.
- (3) Wipe off any dirt on the surface using a dry cloth. If dirt is difficult to remove, clean it according to the procedures below.

Cleaning

1. Thoroughly wipe all surfaces with sufficiently saturated cleaner disinfectant wipes until completely wet and visible contamination is removed.
 - a. Use as many wipes as necessary to remove visible signs of contamination.
 - b. Pay attention to hard-to-clean areas, such as crevices and mated surfaces. Use extra wipes as needed for hard-to-clean areas. Use a sterile cotton swab to push the wipe into crevices.
2. Check all surfaces for cleanliness. If soiling is still visible, repeat the cleaning steps above.
3. To remove cleaner residue, moisten at least one lint-free cloth with water and thoroughly wipe the cleaned surfaces.
4. Allow surfaces to air dry completely before use.
5. Dispose of cleaning materials according to federal, state, and local regulations.

Disinfection

1. Thoroughly wipe all surfaces with sufficiently saturated cleaner disinfectant wipes until completely wet.
 - a. Use as many wipes as necessary to wet surface.
 - b. Pay attention to hard-to-clean areas, such as crevices and mated surfaces. Use extra wipes as needed for hard-to-clean areas. Use a sterile cotton swab to push the wipe into crevices.
2. Ensure that the areas to be disinfected remain visibly wet for at least **two (2) minutes**.
 - a. Additional wipes may be used to keep surfaces wetted with the disinfectant.
3. To remove disinfectant residue, moisten at least one lint-free cloth with water and thoroughly wipe the disinfected surfaces.
4. Allow surfaces to air dry completely before use.

Dispose of cleaning materials according to federal, state, and local regulations.

6.2 Maintenance

No regularly scheduled maintenance is required for the RF coil.

6.3 Service

Please contact your Siemens Healthineers representative with questions regarding service of the RF coil.

6.4 Disposal

Please follow local regulations for the disposal of electrical equipment. Do not dispose of the RF coil in unsorted waste bins. Contact your Siemens Healthineers representative with questions regarding the return or disposal of the RF coil.

6.5 Expected Service Life

This RF coil is designed for an expected service life of at least 6 years under normal usage conditions. The coil is safe to use beyond the expected service life as long as information in the Safety section is followed and Quality Assurance tests pass.

Chapter 7 – Performance Characteristics

7.1 Technical Specifications

Number of Channels	12
RF Coil Type	Receive-Only
Field Strength	0.55T
Frequency	23.6 MHz
Conformance	IEC 60601-1, IEC 60601-1-2, IEC 60601-2-33, NEMA MS6, NEMA MS9, NEMA MS14, ISO 14971

7.2 Guidance and Manufacturer’s Declaration – Electromagnetic Compatibility (EMC)

This coil requires special attention regarding EMC and must be installed and used in accordance with the EMC guidelines provided in this manual. Only use the RF coil in the environment specified below; electromagnetic compatibility is not ensured in environments other than those specified.

7.2.1 Classification

This RF coil is classified as group 2, class A per CISPR 11 when it is used in combination with an MRI system.

i The emissions characteristics of this equipment make it suitable for use in industrial areas and hospitals (CISPR 11 class A). If it is used in a residential environment (for which CISPR 11 class B is normally required) this equipment might not offer adequate protection to radio-frequency communication services. The user might need to take mitigation measures, such as relocating or re-orienting the equipment.

7.2.2 Environment and Compatibility

This RF coil is intended to be used in combination with an MRI system that resides in an RF-shielded scan room within a specialized healthcare facility. All cables and accessories are part of the RF coil and cannot be removed or replaced by the user.

 CAUTION	<ol style="list-style-type: none"> 1. Failure to use this equipment in the specified type of shielded location could result in degradation of the performance of this equipment, interference with other equipment or interference with radio services. 2. Use of this equipment adjacent to or stacked with other equipment should be avoided because it could result in improper operation. If such use is necessary, this equipment and the other equipment should be observed to verify that they are operating normally. 3. Use of accessories and cables other than those specified or provided in this manual could result in increased electromagnetic emissions or decreased electromagnetic immunity of this equipment and result in improper operation. 4. Portable RF communications equipment (including peripherals such as antenna cables and external antennas) should be used no closer than 30 cm (12 inches) to any part of the RF coil, including cables specified by the manufacturer. Otherwise, degradation of the performance of this equipment could result.
---	---

7.2.3 Electromagnetic Emission

The RF coil can only function when connected to the MRI system, which is contained within an RF-shielded environment. Therefore, IEC 60601-1-2 clause 7 regarding electromagnetic emission does not apply.

7.2.4 Electromagnetic Immunity

This RF coil complies with IEC 60601-1-2 clause 8 when used in the specified electromagnetic environment.

Immunity Test	Test and Compliance Level
Electrostatic discharge (ESD), contact discharge	IEC 61000-4-2 ±2kV, ±4kV, ±6kV, ±8 kV
Electrostatic discharge (ESD), air discharge	IEC 61000-4-2 ±2kV, ±4kV, ±8kV, ±15kV



Manufacturer:

Quality Electrodynamics, LLC. (QED)
6655 Beta Drive, Suite 100
Mayfield Village, OH 44143
U.S.A.

www.qualityelectrodynamics.com



Authorized Representative in Europe:

EMERGO EUROPE
Westervoortsedijk 60
6827 AT Arnhem
The Netherlands

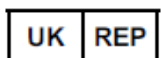

UK Responsible Person:

Emergo Consulting (UK) Limited
c/o Cr360 - UL International
Compass House, Vision Park Histon
Cambridge, CB24-9BZ
United Kingdom



Swiss Authorized Representative:

MedEnvoy Switzerland
Gotthardstrasse 28
6302 Zug
Switzerland

Date of First Issue: 2026-02/ Revision Date: 2026-04